



KERN & Sohn GmbH

Ziegelei 1

D-72336 Balingen

E-Mail: info@kern-sohn.com

Tel: +49-[0]7433- 9933-0

Fax: +49-[0]7433-9933-149

Internet: www.kern-sohn.com

Operating instruction Precision balances

KERN 440

Version 4.3

10/2016

GB



440-BA-e-1643



KERN 440

Version 4.3 10/2016

Operating Manual

Compact balance

Table of Contents

1	Technical Data	4
2	Declaration of conformity	7
3	Basic Information (General).....	8
3.1	Proper use.....	8
3.2	Improper Use	8
3.3	Warranty	8
3.4	Monitoring of Test Resources.....	8
4	Basic Safety Precautions	9
4.1	Pay attention to the instructions in the Operation Manual	9
4.2	Personnel training	9
5	Transportation & Storage.....	9
5.1	Testing upon acceptance	9
5.2	Packaging.....	9
6	Unpacking, Setup and Commissioning	9
6.1	Installation Site, Location of Use.....	9
6.2	Unpacking / setup.....	10
6.3	Mains connection	10
6.4	Operation using a (rechargeable) battery (optional)	11
6.5	Connection of peripheral devices.....	11
6.6	Initial Commissioning	12
6.7	Adjustment.....	12
6.8	Underfloor weighing.....	13
7	Operation elements	14
7.1	Keyboard overview.....	14
8	Basic Operation	15
	Start-up.....	15
	Switching Off	15
	Weighing.....	15
	Taring.....	15
	PRE-TARE-Function	16
	Plus/minus weighings.....	17
	Parts counting	17
	Net-total weighings	18
	Percent determination.....	19

9	Menu	20
9.1	Navigation in the menu	20
9.2	Menu overview	23
9.3	Description of individual menu items	25
	Weighing Units	25
	Dosing and Zero-tracking	26
	Selection adjustment weight	27
	Filter	28
	Display background illumination	28
	Animal weighing function	29
	Reset to factory setting	29
9.4	Interface parameters	30
	Data transfer mode	30
	printout	31
	Baud rate	31
10	Data output RS 232 C	32
10.1	Technical Data	32
10.2	Pin allocation of balance output bushing:	32
10.3	Explanation of the data transfer	32
10.3.1	Pr PC	32
10.3.2	AU Pr	33
10.3.3	AU PC	33
10.3.4	rE Cr	34
10.4	Output on bar code printer	35
11	Service, maintenance, disposal	35
11.1	CLEANING	35
11.2	Service, maintenance	35
11.3	Disposal	35
12	Instant help	36

1 Technical Data

KERN	440-21N	440-21A	440-33N
Readability (d)	0.001 g	0.001 g	0.01 g
Weighing range (max)	40 g	60 g	200 g
Taring range (subtractive)	40 g	60 g	200 g
Reproducibility	0.001 g	0.001 g	0.01 g
Linearity	± 0.003 g	± 0.003 g	± 0.02 g
Minimum unit weight at piece counting	0.002 g	0.002 g	0.02 g
Warm-up time	2 hours	2 hours	30 minutes
Reference quantities at piece counting	5, 10, 25, 50		
Weighing Units	Details „Weighing units“ chapter 9.3		
Recommended adjustment weight, not added (class)	40g (F1)	50g (F2)	200g (M1)
Stabilization time (typical)	3 sec.		
Operating temperature	+ 5° C + 35° C		
Humidity of air	max. 80 % (not condensing)		
Housing (B x D x H) mm	165 x 230 x 80		
Weighing plate mm	Ø 81	Ø 81	Ø 105
Weight kg (net)	1.0	1.0	1.0
Underfloor weighing	-	-	Standard
Flush-mounted hook	-	-	Option

KERN	440-35N	440-35A	440-43N	440-45N
Readability (d)	0.01 g	0.01 g	0.1 g	0.1 g
Weighing range (max)	400 g	600 g	400 g	1000 g
Taring range (subtractive)	400 g	600 g	400 g	1000 g
Reproducibility	0.01 g	0.01 g	0.1 g	0.1 g
Linearity	± 0.03 g	± 0.03 g	± 0.2 g	± 0.2 g
Minimum unit weight at piece counting	0.02 g	0.02 g	0.2 g	0.2 g
Warm-up time	2 hours	2 hours	10 minutes	30 minutes
Reference quantities at piece counting	5, 10, 25, 50			
Weighing Units	Details „ Weighing units “ chapter 9.3			
Recommended adjustment weight, not added (class)	400g (F2)	500g (F2)	400 g (M2)	1000 g (M1)
Stabilization time (typical)	3 sec.			
Operating temperature	+ 5° C + 35° C			
Humidity of air	max. 80 % (not condensing)			
Housing (B x D x H) mm	165 x 230 x 80			
Weighing plate mm	Ø 105	Ø 105	130 x 130	130 x 130
Weight kg (net)	1.0	1.0	1.0	1.0
Underfloor weighing	Standard			
Flush-mounted hook	Option			

KERN	440-47N	440-49N	440-49A
Readability (d)	0.1 g	0.1 g	0.1 g
Weighing range (max)	2000 g	4000 g	6000 g
Taring range (subtractive)	2000 g	4000 g	6000 g
Reproducibility	0.1 g	0.1 g	0.1 g
Linearity	± 0.2 g	± 0.3 g	± 0.3 g
Minimum unit weight at piece count	0.2 g	0.2 g	0.2 g
Warm-up time	30 minutes	2 hours	2 hours
Reference unit weights at piece count	5, 10, 25, 50		
Weighing Units	Details „ Weighing units “ chapter 9.3		
Recommended adjustment weight, not added (class)	2000 g (M1)	4000 g (F2)	5000 g (F2)
Stabilization time (typical)	3 sec.		
Operating temperature	+ 5° C + 35° C		
Humidity of air	max. 80 % (not condensing)		
Housing (B x D x H) mm	165 x 230 x 80		
Weighing plate mm	130 x 130	150 x 170	150 x 170
Weight kg (net)	1.0	1.0	1.0
Underfloor weighing	Standard		
Flush-mounted hook	Option		

KERN	440-51N	440-53N	440-55N
Readability (d)	1 g	1 g	0.2 g
Weighing range (max)	4000 g	6000 g	6000 g
Taring range (subtractive)	4000 g	6000 g	6000 g
Reproducibility	1 g	1 g	0.2 g
Linearity	± 2 g	± 2 g	± 0.6 g
Minimum unit weight at piece count	2 g	2 g	0.4 g
Warm-up time	10 minutes	30 minutes	2 hours
Reference unit weights at piece count	5, 10, 25, 50		
Weighing Units	Details „ Weighing units “ chapter 9.3		
Recommended adjustment weight, not added (class)	4000 g (M2)	5000 g (M2)	5000 g (F2)
Stabilization time (typical)	3 sec.		
Operating temperature	+ 5° C ... + 35° C		
Humidity of air	max. 80 % (not condensing)		
Housing (B x D x H) mm	165 x 230 x 80		
Weighing plate mm	150 x 170	150 x 170	150 x 170
Weight kg (net)	1.0	1.0	1.0
Underfloor weighing	Standard		
Flush-mounted hook	Option		

2 Declaration of conformity

To view the current EC/EU Declaration of Conformity go to:

www.kern-sohn.com/ce

3 Basic Information (General)

3.1 Proper use

The balance you purchased is intended to determine the weighing value of material to be weighed. It is intended to be used as a “non-automatic” balance, i.e. the material to be weighed is manually and carefully placed in the centre of the weighing plate. As soon as a stable weighing value is reached the weighing value can be read.

3.2 Improper Use

Do not use balance for dynamic weighing. In the event that small quantities are removed or added to the material to be weighed, incorrect weighing results can be displayed due to the “stability compensation” in the balance. (Example: Slowly draining fluids from a container on the balance). Do not leave permanent load on the weighing plate. This may damage the measuring system. Impacts and overloading exceeding the stated maximum load (max) of the balance, minus a possibly existing tare load, must be strictly avoided. Balance may be damaged by this.

Never operate balance in explosive environment. The serial version is not explosion protected.

The structure of the balance may not be modified. This may lead to incorrect weighing results, safety-related faults and destruction of the balance.

The balance may only be used according to the described conditions. Other areas of use must be released by KERN in writing.

3.3 Warranty

Warranty claims shall be voided in case

- Our conditions in the operation manual are ignored
- The appliance is used outside the described uses
- The appliance is modified or opened
- Mechanical damage and damage caused by media, liquids
- Natural wear and tear
- The appliance is improperly set up or incorrectly electrically connected
- The measuring system is overloaded

3.4 Monitoring of Test Resources

In the framework of quality assurance the measuring-related properties of the balance and, if applicable, the testing weight, must be checked regularly. The responsible user must define a suitable interval as well as type and scope of this test. Information is available on KERN's home page (www.kern-sohn.com) with regard to the monitoring of balance test substances and the test weights required for this. In KERN's accredited DKD calibration laboratory test weights and balances may be calibrated (return to the national standard) fast and at moderate cost.

4 Basic Safety Precautions

4.1 Pay attention to the instructions in the Operation Manual



Carefully read this operation manual before setup and commissioning, even if you are already familiar with KERN balances.

Versions in other languages are non-binding translations.
The only binding version is the original document in German.

4.2 Personnel training

The appliance may only be operated and maintained by trained personnel.

5 Transportation & Storage

5.1 Testing upon acceptance

When receiving the appliance, please check packaging immediately, and the appliance itself when unpacking for possible visible damage.

5.2 Packaging

Keep all parts of the original packaging in case you need to return the appliance.

Only use original packaging for returning.

Before sending, disconnect all connected cables and loose/movable parts.

Attach possibly existing transport safeguards. Secure all parts, e.g. weighing plate, mains adapter etc., to prevent slipping and damage.

6 Unpacking, Setup and Commissioning

6.1 Installation Site, Location of Use

The balances are designed in a way that reliable weighing results are achieved in common conditions of use.

You will work accurately and fast, if you select the right location for your balance.

Therefore, observe the following for the installation site:

- Place the balance on a firm, level surface;
- Avoid extreme heat as well as temperature fluctuation caused by installing next to a radiator or in the direct sunlight;
- Protect the balance against direct draughts due to open windows and doors;
- Avoid jarring during weighing;
- Protect the balance against high humidity, vapors and dust;
- Do not expose the device to extreme dampness for longer periods of time. Non-permitted condensation (condensation of air humidity on the appliance) may occur if a cold appliance is taken to a considerably warmer environment. In this case, acclimatize the disconnected appliance for ca. 2 hours at room temperature.
- Avoid static charge of goods to be weighed and weighing container.

Major display deviations (incorrect weighing results) may be experienced should electromagnetic fields (e.g. due to mobile phones or radio equipment), static electricity accumulations or instable power supply occur. Change location or remove source of interference.

6.2 Unpacking / setup

Carefully remove the balance from the packaging, remove plastic cover and setup balance at the intended workstation.

The balance must be installed in a way that the weighing plate is exactly in horizontal position.

At the models 440-21N and 440-21A the transport securing must be removed before the weighing plate is mounted.

Scope of delivery / serial accessories

- Balance (incl. protective cover)
- Weighing plate
- Mains power supply
- Operating Manual
- Windshield (440-21N, 440-21A)

6.3 Mains connection

Power is supplied via the external mains adapter. The stated voltage value must be the same as the local voltage.

Only use original KERN mains adapters. Using other makes requires consent by KERN.

6.4 Operation using a (rechargeable) battery (optional)

Lift-off the battery cover on the lower side of the balance. Connect 9 V compound battery.

Replace the battery compartment cover.

For battery operation the balance has an automatic switch-off function which can be activated or deactivated in the menu (chapter 9).

- ⇒ In weighing mode keep the **PRINT**-key pressed until [Unit] appears.
- ⇒ Press **MODE** key repeatedly until „AF“ appears.
- ⇒ Use the **SET** key, to confirm.
- ⇒ Use the **MODE** key to choose between the two following settings:

„**AF on**“: In order to save the battery, the balance switches automatically off after 3 minutes without weighing.

„**AF off**“: Switch-off function deactivated.

- ⇒ Use the **SET** key to confirm. The balance returns to weighing mode.

If the batteries are run down, "LO" appears in the display. Press **ON/OFF**-key and replace the batteries immediately.

If the balance is not used for a longer time, take out the batteries and store them separately. Leaking battery liquid could damage the balance.

If there exists an optional rechargeable battery, it has to be connected in the battery compartment via a separate plug-in socket. Now the mains adapter delivered with the rechargeable battery must be applied.

6.5 Connection of peripheral devices

Before connecting or disconnecting of additional devices (printer, PC) to the data interface, always disconnect the balance from the power supply.

With your balance, only use accessories and peripheral devices by KERN, as they are ideally tuned to your balance.

6.6 Initial Commissioning

In order to obtain exact results with the electronic balances, your balance must have reached the operating temperature (see warming up time chap. 1). During this warming up time the balance must be connected to the power supply (mains, accumulator or battery).

The accuracy of the balance depends on the local acceleration of gravity. Strictly observe hints in chapter Adjustment.

6.7 Adjustment

As the acceleration value due to gravity is not the same at every location on earth, each balance must be coordinated - in compliance with the underlying physical weighing principle - to the existing acceleration due to gravity at its place of location (only if the balance has not already been adjusted to the location in the factory). This adjustment process must be carried out for the first commissioning, after each change of location as well as in case of fluctuating environment temperature. To receive accurate measuring values it is also recommended to adjust the balance periodically in weighing operation.

The adjustment should be made with the recommended adjustment weight (see chap. 1 "Technical data"). Adjustment is also possible with the weights of other nominal values (see table 1), but not the optimum for measuring technique.

Procedure when adjusting:

Observe stable environmental conditions. A warming up time (see chapter 1) is required for stabilization.

- ⇒ Turn on balance by pressing the **ON/OFF** key.
- ⇒ Press the **MODE** key and keep it pressed, after the acoustic signal there appears in the display for short time „CAL“. After that the exact size appears flashing in the display (see chapter.9.3) of the adjustment weight.
- ⇒ Now set the adjusting weight in the centre of the weighing plate.
- ⇒ Press the **SET** key. Short time later there appears „**CAL F**“, then the automatic return to the weighing mode. In the display there appears the value of the adjustment weight.

An error during adjustment or the use of an incorrect adjusting weight will result in an error message „**CAL E**“. Repeat adjustment.

Keep the adjustment close to the balance. Daily control of the weighing exactness is recommended for quality-relevant applications.

6.8 Underfloor weighing

Objects unsuitable for placing on the weighing scale due to size or shape may be weighed with the help of the flush-mounted platform.

Proceed as follows:

- Switch off the balance
- Open closing cover at the balance bottom.
- Suspend hook for underfloor weighing carefully and completely.
- Place weighing balance over an opening.
- Attach load to hook and carry out weighing procedure.



Fig. 1: Setup of balance for underfloor weighing



CAUTION

- Always ensure that all suspended objects are stable enough to hold the desired goods to be weighed safely (danger of breaking).
- Never suspend loads that exceed the stated maximum load (max) (danger of breaking)
- Always ensure that there are no persons, animals or objects that might be damaged underneath the load.



After completing the underfloor weighing the opening on the bottom of the balance must always be closed (dust protection).

7 Operation elements



7.1 Keyboard overview

Key	Designation	Function
PRINT	PRINT -key	<ul style="list-style-type: none"> • Calculate weighing data via interface • Call up menu (keep key pressed until UNIT appears)
SET/M	SET key	<ul style="list-style-type: none"> • Confirm settings in the menu • Save and exit menu
MODE/CAL	MODE key	<ul style="list-style-type: none"> • How to select menu items • Change settings in the menu • Adjustment
TARE	TARE key	<ul style="list-style-type: none"> • Taring
ON/OFF	ON/OFF switch	<ul style="list-style-type: none"> • Turn on/off

8 Basic Operation

Start-up



- ⇒ Press **ON** button.
The balance will carry out a self-test. The balance is ready for weighing when the weight display appears.



Switching Off



- ⇒ Press **OFF** button, the display disappears



Weighing

- ⇒ Place goods to be weighed on balance
- ⇒ Wait for standstill control, after the standstill control, the weighing unit appears right hand in the display (e.g. g or kg)
- ⇒ Read weighing result.

If the goods are heavier than the weighing range, the display will show "**Error**" (=Overload), and a whistle is sounded.

Taring

- ⇒ Place an empty weighing container, the weight of the weighing container will be displayed.

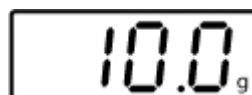

- ⇒ Press the **TARE** button, the zero display disappears. The tare weight is saved until it is deleted.

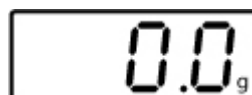

⇒ Weigh the material, the net weight will be indicated.

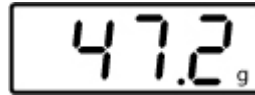

The taring process can be repeated any number of times, e.g. when adding several components for a mixture (adding). The limit is reached when the whole weighing range is exhausted.

The weight of the weighing container will be displayed as a minus number after removing the weighing container.

The tare weight is saved until it is deleted.

Delete tare



⇒ Unload the balance and press the **TARE** button, the zero display appears.



PRE-TARE-Function



Using this function the weight of a tare vessel is stored. Even after turning off/on the weighing balance will continue working with the saved tare value.

- ⇒ In weighing mode put tare vessel on the weighing plate
- ⇒ Press repeatedly the **MODE** key until „PtArE“ flashing appears.
- ⇒ Use **SET** key to store the current weight on the weighing plate as a PRE-TARE value.

Delete PRE-TARE value



- ⇒ Remove all loads from the balance and press repeatedly the **MODE** key until „PtArE“ flashing appears.
- ⇒ Use the **SET** key to confirm. The PRE-TARE value is deleted, the zero display appears.

Plus/minus weighings



For example unit weight control, fabrication control etc.

- ⇒ Put the nominal weight on the weighing plate and tare using the **TARE** button.
- ⇒ Remove the nominal weight
- ⇒ Put the test objects subsequently on the weighing plate, the respective deviation from the nominal weight is displayed with the respective sign to „+“ and „-“.

According to the same procedure also packages with the same weight can be produced, referring to a nominal weight.

- ⇒ Back to weighing mode by pressing the **TARE** button.

Parts counting

During piece counting parts can either be counted into a container or out of a container. To count a greater number of parts the average weight per part has to be determined with a small quantity (reference quantity).

The larger the reference quantity, the higher the counting exactness. High reference must be selected for small parts or parts with considerably different sizes.

The larger the reference quantity, the more accurate the parts counting.

The process has four steps:

- Tare the weighing container
- Determine the reference unit
- Original weighing of reference weight
- Count the items

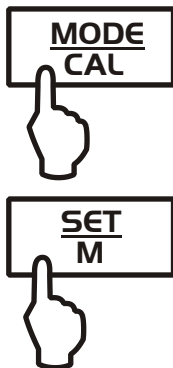

- ⇒ In weighing mode press **MODE** key shortly. Reference piece number „5^{PCS}“ appears flashing.
- ⇒ By pressing the **MODE** button several times other reference quantities **5**, **10**, **20**, **25** and **50** can be called up. Place as many pieces to count on the weighing plate as the set reference quantity requires.
- ⇒ Use the **SET** key to confirm. The balance is now in parts counting mode counting all units on the weighing plate.



- **Back to weighing mode** by pressing the **MODE** button.
- **Error message „Er 1“**
Piece below minimum weight of piece (See chpt. 1 “Technical specifications“): Press **MODE** key and restart reference determination.
- **Taring**
The tare vessels can also be used for piece counting. Before starting piece counting use the **TARE** button to tare out the container.

Net-total weighings

It is useful if a mixture of several components is weighed into a tare vessel and finally the sum weight of all weighed components is necessary for control purposes (net-total, i.e. the weight of the tare vessel).

Example:

1. Place tare container on the weighing plate. Press the **TARE** button, the zero display disappears.
 2. Weigh-in component **①**. Press the **SET** button, the zero display disappears. [**▲**] is displayed on the right border of the display.
 3. Weigh-in component **②** and press **SET** key. Net-total (sum weight of the components **①** and **②**) is displayed.
 4. Press the **SET** button, the zero display disappears.
 5. Weigh-in component **③** and press **SET** key. Net-total (sum weight of the components **①** and **②** and **③**.) is displayed.
- ⇒ If necessary, also fill the formula up to the desired final value. For every component more repeat the steps 4-5.
- ⇒ Back to weighing mode by pressing the **TARE** button.

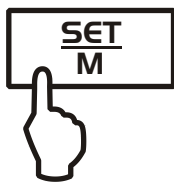

Percent determination

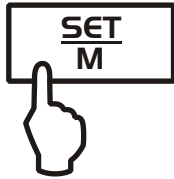

Percentage calculation facilitates weight display in percent related to a reference weight equivalent to 100 %.

- ⇒ In weighing mode press **MODE** key repeatedly, until [**100 %**] is displayed.
- ⇒ Put a reference weight which corresponds to 100 %.
- ⇒ Store by pressing the **SET** key. Remove reference weight.
- ⇒ Place goods to be weighed on balance.
The weight of the sample is displayed in percentage in terms of the reference weight.

Back to weighing mode by pressing the **MODE** button.

9 Menu

9.1 Navigation in the menu

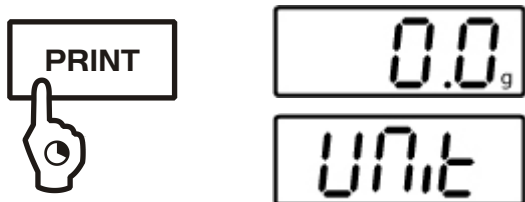
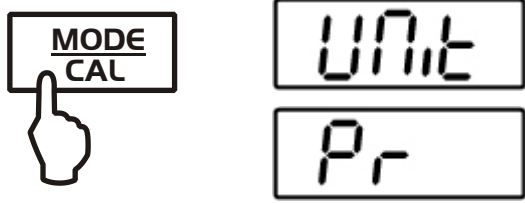
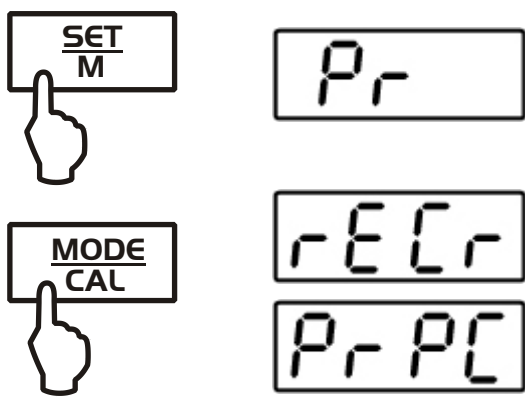
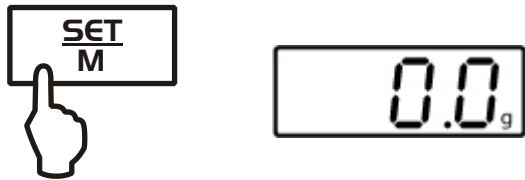
<p>Access to menu</p>  <p>The diagram shows a hand pointing to the PRINT key. To the right, the display shows 0.0_g in the top line and Unit in the bottom line.</p>	<p>In weighing mode keep the PRINT key pressed until [Unit] appears.</p>
<p>How to select menu items</p>  <p>The diagram shows a hand pointing to the MODE CAL key. To the right, the display shows Unit in the top line and Pr in the bottom line.</p>	<p>Using the MODE key the individual menu items can be selected one after the other.</p>
<p>How to change settings</p>  <p>The diagram shows a hand pointing to the SET M key, then the MODE CAL key. To the right, the display shows Pr in the top line, rETr in the middle line, and Pr PC in the bottom line.</p>	<p>Acknowledge selected menu item using SET key, the current setting is displayed.</p> <p>Change the settings using the MODE key. At any pressing of the MODE key, the next setting is displayed, see chapter 9.2 „Menu Overview“.</p>
<p>1. Save change of a menu item and exit the menu</p>  <p>The diagram shows a hand pointing to the SET M key. To the right, the display shows 0.0_g.</p>	<p>⇒ Press the SET key; balance will return to weighing mode.</p>

2. Change settings of several menu items

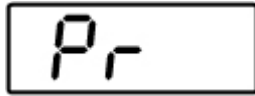
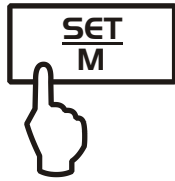

Acknowledge selected menu item using **SET** key, the current setting is displayed.

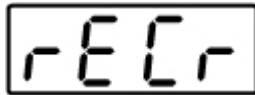

Use the **MODE** key to change settings.

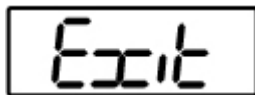
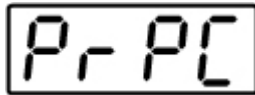

Press the **TARE** key, „Exit“ is displayed.

Either

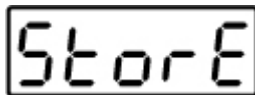
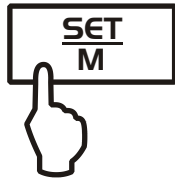

Acknowledge with **SET** key (yes), „Store“ is displayed. Save (**SET** key) or reject (**PRINT** key) and exit the menu,

or

Press **PRINT** key (no) and make the changes on the other menu items as described above

Save/reject and exit the menu

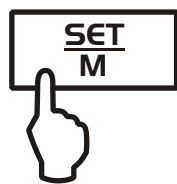

Exit

Store

⇒ Save

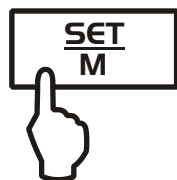

0.0_g

⇒ Reject



0.0_g

Either

Any changes carried out are stored by pressing the **SET** key (yes). The balance returns automatically into weighing mode.

or

To cancel changes, press the **PRINT** key (no). The balance returns automatically into weighing mode.

9.2 Menu overview

Description of function	Function	Parameter	Description of options
Weighing units switching over (see chapter 9.3).	UNIT	g*	Gram
		kg	Kilogram (dependent on model)
		oz	Pound
		ozt	Ounce
		lb	Troy ounce
		tih	Tael Hongkong
		tlt	Tael Taiwan
		gn	Grain (dependent on model)
		dwt	Pennyweight (dependent on model)
		mo	Momme
		Tol	Tola
		ct	Carat (dependent on model)
FFA	Freely selectable factor		
Data transfer mode (see chapter 9.4)	Pr	rE CR*	Data output via remote control commands (see chapter 10.3)
		Pr PC	Data output by pressing the PRINT key (see chapter 10.3)
		AU PC	Continuous data output (see chapter 10.3)
		bA Pr	Printout on barcode printer (see chapter 10.4)
		AU Pr	Autom. Data output of stable weighing values (see chapter 10.3)
Selection printer output (see chapter 9.4)	LAPr	Hdr*	Edition of the headlines
		GrS	Edition of the total weight
		Net	Edition of the net weight
		tAr	Edition of the tare weight
		N7E	Edition of the stored weight
		PCS	Edition of quantity
		AUJ	Edition of the unit weight
		Rqt	Edition of the reference quantity
		FFd	Edition of a page feeding at start printer output
FFE	Edition of a page feeding at end printer output		

Baud rate (see chapter 9.4).	bAUd	19200	
		9600*	
		4800	
		2400	
Auto off (battery operation), see chap. 6.4	AF	on*	Automatic switch-off function after 3 min without changing load ON
		off	Automatic switch-off function after 3 min without changing load OFF
Auto Zero (see chapter 9.3)	tr	on*	On
		off	Off
Selection adjustment weight (see chapter 9.3)	CAL	100	*dependent on model
		200	
		300	
Filter function (see chapter 9.3), only models 440-21A, 440-35A, 440-49A	StAbiL	1	Fast display
		2	Normal display
		3	Slow display
Background illumination of the display, (see chap. 9.3)	bL	on*	Background illumination on
		off	Background illumination off
		CH	The background illumination will be switched off automatically 10 sec after having reached a stable weighing value.
Animal weighing function (see chapter 9.3)	ANL	off*	Off
		3	Period 3 seconds
		5	Period 5 seconds
		10	Period 10 seconds
		15	Period 15 seconds
Reset to factory setting (see chap. 9.3)	rSt	no*	no
		yes	yes

* = default setting

9.3 Description of individual menu items

Weighing Units

- ⇒ In weighing mode keep the **PRINT** key pressed until **[Unit]** appears.



- ⇒ Press **SET** key, the selected unit is displayed.
- ⇒ Use the **MODE** key to select between the different units (see following table).
- ⇒ Use the **SET** key to confirm the selected unit

	Display	Conversion factor 1 g =
Gram	g	1.
Ounce	oz	0.035273962
Troy ounce	ozt	0.032150747
Pound	lb	0.0022046226
Tael Hongkong	tlh	0.02671725
Tael Taiwan	tlt	0.0266666
Grain (dependent on model)	gn	15.43235835
Pennyweight (dependent on model)	dwt	0.643014931
Momme	(mom)	0.2667
Tola	tol	0.0857333381
Carat (dependent on model)	ct	5
Freely selectable factor *)	FFA	xx.xx

*) Input conversion factor

- ⇒ As specified above, press repeatedly the **MODE** key until „**FFA**“ appears.
- ⇒ To enter the factor, press the **SET** key; the enabled digit starts flashing.
Using the **MODE** button, the displayed value is increased by 1, with the **PRINT** button it is reduced by 1.
With the **TARE** key selection of the number to the left.
- ⇒ Confirm input by pressing the **SET** key.
- ⇒ Press repeatedly the **SET** key to take over the „Freely selectable factor“ as current weighing unit.

The different weighing models have integrated different foreign weighing units. Details can be seen in this table:

Model \ Units	440-21N	440-21A	440-33N	440-35N	440-35A	440-43N	440-45N	440-47N	440-49N	440-49A	440-51N	440-53N	440-55N
Gram	X	X	X	X	X	X	X	X	X	X	X	X	X
Pound			X	X	X	X	X	X	X	X	X	X	X
Ounce	X	X	X	X	X	X	X	X	X	X	X	X	X
Troy ounce	X	X	X	X	X	X	X	X	X	X	X	X	X
Tael Hongkong	X	X	X	X	X	X	X	X	X	X	X	X	X
Tael Taiwan	X	X	X	X	X	X	X	X	X	X	X	X	X
Grain	X	X	X	X	X								X
Pennyweight	X	X	X	X	X	X	X	X	X	X	X	X	X
Momme	X	X	X	X	X	X	X	X	X	X	X	X	X
Tola	X	X	X	X	X	X	X	X	X	X	X	X	X
Carat	X	X	X	X	X								
Freely selectable factor	X	X	X	X	X	X	X	X	X	X	X	X	X

Dosing and Zero-tracking The Auto-Zero function is used to tare small variations in weight automatically.

In the event that small quantities are removed or added to the material to be weighed, incorrect weighing results can be displayed due to the “stability compensation“ in the balance. (Example: Slowly draining fluids from a container on the balance). When apportioning involves small variations of weight, it is advisable to switch off this function.

If **Zero-Tracking** however is switched off, the weighing display becomes more busy.

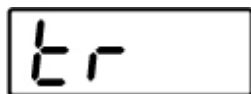
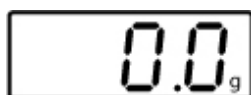

- ⇒ In weighing mode keep the **PRINT** key pressed until **[Unit]** appears.
- ⇒ Press the **MODE** button several times until „tr“ is displayed.
- ⇒ Acknowledge using **SET** key, the current setting is displayed.
- ⇒ Select the desired settings by pressing the **MODE** key.

tr	on	Function activated
tr	off	Function deactivated

- ⇒ Use the **SET** key to confirm selection.

**Selection
adjustment
weight**

In the model series KERN FKB_A, the adjustment weight can be selected from three pre-set nominal values (approx. 1/3; 2/3; max) (refer also to following table, factory setting with grey background). In order to achieve high-quality weighing results in the sense of the measuring technology, it is recommended to select the nominal value as high as possible. The non delivered adjustment weights can be purchased from KERN as option.

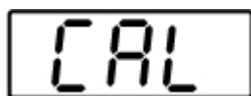
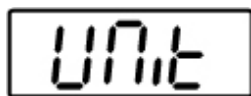
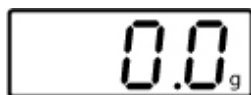

- ⇒ In weighing mode keep the **PRINT** key pressed until **[Unit]** appears.
- ⇒ Press the **MODE** key several times until „**CAL**“ is displayed.
- ⇒ Acknowledge using **SET** key, the current setting is displayed.
- ⇒ Select the desired settings by pressing the **MODE** key.
- ⇒ Use the **SET** key to confirm selection.

440-21N	440-21A	440-33N	440-35N	440-35A	440-43N	440-45N
10g	10g	50g	100g	100g	100g	200g
20g	20g	100g	200g	200g	200g	500g
30g	40g	150g	300g	400g	300g	700g
40g	50g	200g	400g	500g	400g	1000g
	60g			600g		

440-47N	440-49N	440-49A	440-51N	440-53N	440-55N
500g	1000g	1000g	1000g	1000g	1000g
1000g	2000g	2000g	2000g	2000g	2000g
1500g	3000g	5000g	3000g	5000g	5000g
2000g	4000g	6000g	4000g	6000g	6000g

Filter

Only models 440-21A,
440-35A, 440-49A

0.0_g

Unit

StAbiL

StAbiL₂

(example)

This menu item allows the balance to be set according to specific ambient conditions and measuring purposes.

- ⇒ In weighing mode keep the **PRINT** key pressed until **[Unit]** appears.
- ⇒ Press the **MODE** button several times until „**StAbiL**“ is displayed.
- ⇒ Acknowledge using **SET** button, the current setting is displayed.
- ⇒ Select the desired settings by pressing the **MODE** button.

1	Filter 1: The balance reacts quickly and in a sensitive manner, quiet set-up location.
2	Filter 2: The scale reacts normally, normal installation site
3	Filter 3: The balance reacts slowly and in a robust manner, busy set-up location

- ⇒ Use the **SET** key to confirm selection.

Display background illumination

0.0_g

Unit

bl

- ⇒ In weighing mode keep the **PRINT** key pressed until **[Unit]** appears.
- ⇒ Press the **MODE** button several times until „**bl**“ is displayed.
- ⇒ Acknowledge using **SET** key, the current setting is displayed.
- ⇒ Select the desired settings by pressing the **MODE** key.

bl	on	Background illumination switched on	Contrastful display which can also be red in the darkness.
bl	off	Background illumination switched off	Battery saving
bl	Ch	The background illumination will be switched off automatically 10 sec after having reached a stable weighing value.	Battery saving

- ⇒ Use the **SET** key to confirm selection.

Animal weighing function



The animal weighing function can be applied for busy weighing. During a defined period the average value of the weighing results is formed.

The more unquiet the weighed item, the longer the period should be selected.

- ⇒ In weighing mode keep the **PRINT** key pressed until **[Unit]** appears.
- ⇒ Press the **MODE** button several times until „ANL“ is displayed.
- ⇒ Acknowledge using **SET** key, the current setting is displayed.
- ⇒ Select the desired settings by pressing the **MODE** key

ANL	3	Period 3 seconds
ANL	5	Period 5 seconds
ANL	10	Period 10 seconds
ANL	15	Period 15 seconds
ANL	off	Animal weighing not active

- ⇒ Use the **SET** key to confirm selection.
- ⇒ Put the weighing good (animal) on the weighing plate and press the **SET** button. In the display runs a „Countdown“. The average value of the weighing results is displayed and remains displayed on the screen.
- ⇒ Use the **SET** key to change between animal weighing and normal weighing.
- ⇒ Press the **SET** key to restart the weighing cycle for animal weighing.

Reset to factory setting

This function resets all balance settings to factory setting.

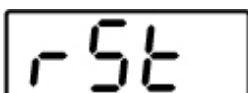
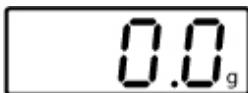

- ⇒ In weighing mode keep the **PRINT** key pressed until **[Unit]** appears.
- ⇒ Press the **MODE** button several times until „rSt“ is displayed.
- ⇒ Acknowledge using **SET** key, the current setting is displayed.
- ⇒ Select the desired settings by pressing the **MODE** key

rSt	yes	Balance will be reset to factory setting.
rSt	no	The balance keeps its individual setting

- ⇒ Use the **SET** key to confirm selection. The balance returns to weighing mode.

9.4 Interface parameters

Data output is carried out via interface RS 232 C.

General

The previous condition for the data transfer between balance and a peripheral device (e.g. printer, PC ...) is that the appliances are set to the same interface parameters (e.g. baud rate, transfer mode ...).

Data transfer mode

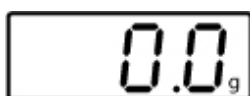

⇒ In weighing mode keep the **PRINT** key pressed until **[Unit]** appears.

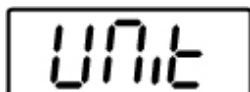

⇒ Press the **MODE** button several times until „Pr“ is displayed.

⇒ Acknowledge using **SET** key, the current setting is displayed.

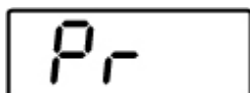

⇒ Select the desired settings by pressing the **MODE** key

rE CR	Data output via remote control commands
Pr PC	Data output using the PRINT key
AU PC	Continuous data output
bA Pr	Output on bar code printer
AU Pr	Autom. data output of stable weighing values

⇒ Use the **SET** key to confirm selection. The balance returns to weighing mode.

printout

Using this function data are selected which are to be sent via the RS232C (**not** valid for data transfer mode BAPr).

- ⇒ In weighing mode keep the **PRINT** key pressed until **[Unit]** appears.
- ⇒ Press the **MODE** key several times until „LAPr“ is displayed.
- ⇒ Acknowledge using **SET** key, the current setting is displayed.
- ⇒ Select the desired output parameter by pressing the **MODE** key

Hdr	Edition of the headlines
GrS	Edition of the total weight
Net	Edition of the net weight
tAr	Edition of the tare weight
N7E	Edition of the stored weight
PCS	Edition of quantity
AUJ	Edition of the unit weight
Rqt	Edition of the reference quantity
FFd	Edition of a page feeding at start printer output
FFE	Edition of a page feeding at end printer output

- ⇒ After actuating the SET button, the current state is displayed (on / off).
- ⇒ Use MODE and PRINT key to change the status „on ⇌ off“.
- ⇒ Use the SET key to confirm selection. The balance returns to weighing mode.



Baud rate

By that way the user can configure his own data block, which then is sent to a printer or to a PC.

The baud rate defines the transfer speed via the interface, 1 Baud = 1 Bit/second.

- ⇒ In weighing mode keep the **PRINT** key pressed until **[Unit]** appears.
- ⇒ Press the **MODE** key several times until „bAUD“ is displayed.
- ⇒ Acknowledge using **SET** key, the current setting is displayed.
- ⇒ Use **MODE** key select the desired settings
9600 ⇒ 4800 ⇒ 2400 ⇒ 1200 ⇒ 19200
- ⇒ Use the **SET** key to confirm selection. The balance returns to weighing mode.

10 Data output RS 232 C

10.1 Technical Data

- 8-bit ASCII Code
- 1 start bit, 8 data bits, 1 stop bit, no parity bit
- Baud rate selectable at 1200, 2400, 4800 , **9600** and 19200 baud
- Miniature plug-in necessary (9 pole D-Sub)
- For operation with interface faultless operation is only ensured with the correct KERN – interface cable (max. 2m)

10.2 Pin allocation of balance output bushing:

Front view:

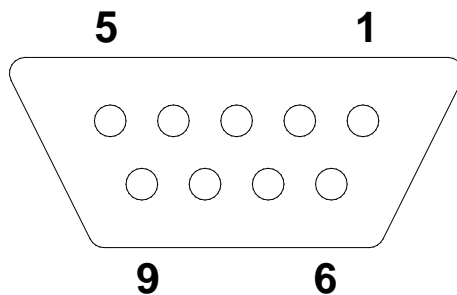

Pin 2: Transmit data
 Pin 3: Receive data
 Pin 5: Signal ground

10.3 Explanation of the data transfer

10.3.1 Pr PC

Press the PRINT key, at stable value the format is transferred from **LAPR**.

a. Format for stable values for weight/quantity/percentage

1	2	3	4	5	6	7	8	9	10	11	12	13	14	15	16	17	18
B	B	B	B	B	B	B	B	B	0	.	0	B	g	B	B	C	LF
																R	

b. Format in case of fault

1	2	3	4	5	6	7	8	9	10	11	12	13	14
B	B	B	B	B	B	B	E	r	r	o	r	CR	LF

10.3.2 AU Pr

As soon as the weighing value is stable, the format is automatically transferred from LAPR.

c. Format for stable values for weight/quantity/percentage

1	2	3	4	5	6	7	8	9	10	11	12	13	14	15	16	17	18
B	B	B	B	B	B	B	B	B	0	.	0	B	g	B	B	C R	LF

d. Format in case of fault

1	2	3	4	5	6	7	8	9	10	11	12	13	14
B	B	B	B	B	B	B	E	r	r	o	r	CR	LF

10.3.3 AU PC

The weighing values are sent automatically and continuously, no matter if the value is stable or unstable.

e. Format for stable values for weight/quantity/percentage

1	2	3	4	5	6	7	8	9	10	11	12	13	14	15	16	17	18
B	B	B	B	B	B	B	B	B	0	.	0	B	g	B	B	C R	LF

f. Format in case of fault

1	2	3	4	5	6	7	8	9	10	11	12	13	14
B	B	B	B	B	B	B	E	r	r	o	r	CR	LF

g. Format for unstable values for weight/quantity/percentage

1	2	3	4	5	6	7	8	9	10	11	12	13	14	15
B	B	B	B	B	B	B	B	B	0	.	0	B	CR	LF

10.3.4 rE Cr

The remote control commands s/w/t are sent from the remote control unit to the balance as ASCII code. After the balance having received the s/w/t commands, it will send the following data.

Take into account that the following remote control commands must be sent without a subsequent CR LF.

- s** Function: Stable weighing value for the weight is sent via the RS232 interface
- w** Function: Weighing value for the weight (stable or unstable) is sent via the RS232 interface
- t** Function: No data are sent, the balance carries out the tare function.

h. Format for stable values for weight/quantity/percentage

1	2	3	4	5	6	7	8	9	10	11	12	13	14	15	16	17	18
B*	B	B	B	B	B	B	B	B	0	.	0	B	g	B	B	C R	LF

i. Format in case of fault

1	2	3	4	5	6	7	8	9	10	11	12	13	14
B	B	B	B	B	B	B	E	r	r	o	r	CR	LF

j. Format for unstable values for weight/quantity/percentage

1	2	3	4	5	6	7	8	9	10	11	12	13	14	15
B*	B	B	B	B	B	B	B	B	0	.	0	B	CR	LF

SYMBOLS:

- B* = blank or M
- B / 0 / . = blank / weight values / decimal dot, depending on the measuring Value
- g = weight unit / unit / %
- E, o, r = ASCII code or "E, o, r"
- CR = carriage return symbol
- LF = line feed symbol

10.4 Output on bar code printer

The data transfer mode has to be set on „**BA Pr**“ (chapter 9.4).

As bar code printer the Zebra printer model LP2824 is provided.

Take into account that the output format of the balance is fixedly defined and cannot be changed.

The printer format is stored in the printer, i.e. in case of a failure the printer cannot be changed with a new one from factory, previously it is necessary that KERN installs the respective software.

The Zebra printer and the balance must be connected to the delivered interface cable when they are switched off.

After switching-on both appliances, and after reaching the status ready-for-operation, a label will be printed out when pressing the **PRINT** button.

11 Service, maintenance, disposal

11.1 CLEANING

Before cleaning, disconnect the appliance from the operating voltage.

Please do not use aggressive cleaning agents (solvents or similar agents), but a cloth dampened with mild soap suds. Take care that the device is not penetrated by fluids and polish it with a dry soft cloth.

Loose residue sample/powder can be removed carefully with a brush or manual vacuum cleaner.

Spilled weighing goods must be removed immediately.

11.2 Service, maintenance

The appliance may only be opened by trained service technicians who are authorized by KERN.

Before opening, disconnect from power supply.

11.3 Disposal

Disposal of packaging and appliance must be carried out by operator according to valid national or regional law of the location where the appliance is used.

12 Instant help

In case of an error in the program process, briefly turn off the balance and disconnect from power supply. The weighing process must then be restarted from the beginning.

Help:

Fault

Possible cause

- | | |
|--|--|
| The displayed weight does not glow. | <ul style="list-style-type: none">• The balance is not switched on.• The mains supply connection has been interrupted (mains cable not plugged in/faulty).• Power supply interrupted.• Batteries are inserted incorrectly or empty• No batteries inserted. |
| The displayed weight is permanently changing | <ul style="list-style-type: none">• Draught/air movement• Table/floor vibrations• The weighing plate is in contact with foreign matter.• Electromagnetic fields / static charging (choose different location/switch off interfering device if possible) |
| The weighing value is obviously wrong | <ul style="list-style-type: none">• The display of the balance is not at zero• Adjustment is no longer correct.• Great fluctuations in temperature.• Electromagnetic fields / static charging (choose different location/switch off interfering device if possible) |

Should other error messages occur, switch balance off and then on again. If the error message remains inform manufacturer.